

Before use

Please read all the information contained in these operating instructions carefully. They contain important details on the use, safety and maintenance of the appliance. Keep these operating instructions in a safe place and pass them on to further users if necessary.

Observe the safety instructions.

Contents

page

Important safety instructions	2
Attention: Read before starting up the power pack	3
Controls and displays	4
1. Startup	7
2. Energy control	8
3. Modelling light	8
4. Release and remote control	10
5. Flash ready signals visual / audible	10
6. Selecting additional functions	11
7. Protective facilities / Fault indication	11
8. Maintenance of rechargeable batteries	12
9. Lamp bases	13
10. Technical data	15

Important safety instructions

When using your photographic equipment, basic safety precautions should always be followed, including the following:

1. Read and understand all instructions before using.
2. Close supervision is necessary when any appliance is used by or near children. Do not leave appliance unattended while in use.
3. Care must be taken as burns can occur from touching hot parts.
4. Do not operate appliance with a damaged cable or if the appliance has been dropped or damaged - until it has been examined by a qualified serviceman.
5. Position the cable so that it will not be tripped over, pulled, or contact hot surfaces.
6. If an extension cable is necessary, a cable with a current rating at least equal to that of the appliance should be used. Cables rated for less amperage than the appliance may overheat. When using a cable reel, it has to be unrolled before operating to avoid overheating of the cable.
7. Always turn off the power pack before connecting or disconnecting any lamp bases.
8. Always unplug appliance from electrical socket before cleaning and servicing and when not in use. Never jerk cable to pull plug from socket. Grasp plug and pull to disconnect.
9. Let appliance cool completely before putting away. Loop cable loosely around appliance when storing.
10. When putting away or winding up cables, take care they do not get in contact with hot parts of the appliance or lamp bases.
11. To reduce the risk of electric shock, do not immerse this appliance in water or other liquids.
12. To reduce the risk of electric shock, do not disassemble this appliance, but take it to a qualified serviceman when service or repair work is required. Incorrect reassembly can cause electric shock when the appliance is used subsequently.
13. The use of an accessory attachment not recommended by the manufacturer may cause a risk of fire, electric shock, or injury to persons.
14. Connect this appliance only to a broncolor rechargeable battery or to an earthed socket.
15. Prevent metal objects from touching the broncolor battery contact surfaces.

Attention:

Read before starting up the power pack

- Remove protective foil from battery contacts before use the unit.
- Prior to replacing fuses, light bulbs or flash tubes, discharge the power pack and disconnect from power supply. Disconnect the lamp base from the power pack.
- These units are designed for use in dry conditions. Protect them from water and from excessive exposure to dust by using the bag for power pack Mobil art. no. 36.513.00.
- The units are not suitable for use in an environment where there is a risk of explosion.
- The accessories mounted onto the lamp bases may heat up to high temperatures under specific conditions. Handle with care!
- With due allowance for heat radiation, lamp bases with more than 100 W modelling light may be directed against inflammable surfaces only at a minimum distance of 1 m.
- For safety reasons, never operate the lamps without the protecting glass in place.
- Flash light contains, similar to sunlight, a specific portion of UV light. The undesirable side effects on skin and eyes are considerably reduced by using flash tubes and protecting glasses with a UV coating. Without these or other protective filters, use with extreme care when shooting.
- Even when disconnected from the power supply, dangerous voltages may remain inside the unit. For this reason units should be opened by trained personnel only. Excluding exchanging of the rechargeable battery.
- broncolor power packs and lamp bases meet an extremely high safety standard. When connecting broncolor products to other manufacturers' products, integrated safety measures may become ineffective. Due to different design features and contact assignment of the lamp plugs of other makes, the user may even be at risk. We offer no guarantee and accept no liability for damages which may be caused by this type of usage.

Controls and displays

1. Switch "on/off"
2. Switch "eco" for slow charge
3. Battery charger socket for rechargeable battery
4. Sync socket
- 5.1 Outlet I
- 5.2 Outlet II
6. Master power selector "up/down"
7. Slave cell
8. Digital master power display
9. Slave cell on/off
10. IR receiver cell
11. IR receiver on/off
12. - Modelling lamp on/off;
- Choice of the proportional level of modelling light when using with Studio Booster
13. Test key, green ready lamp
14. Display charge state of the battery
15. Rechargeable plug-in battery

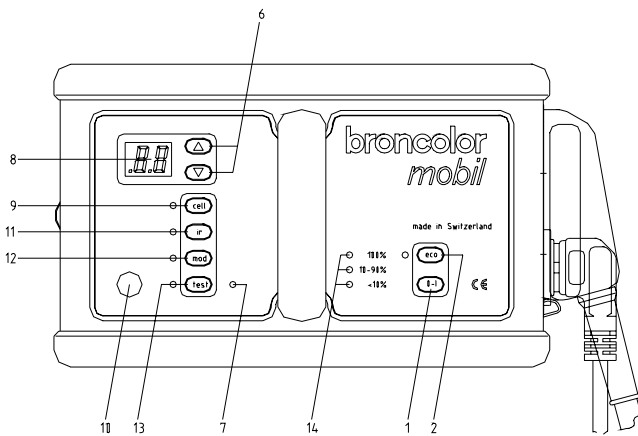
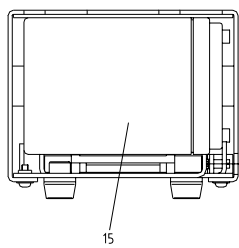
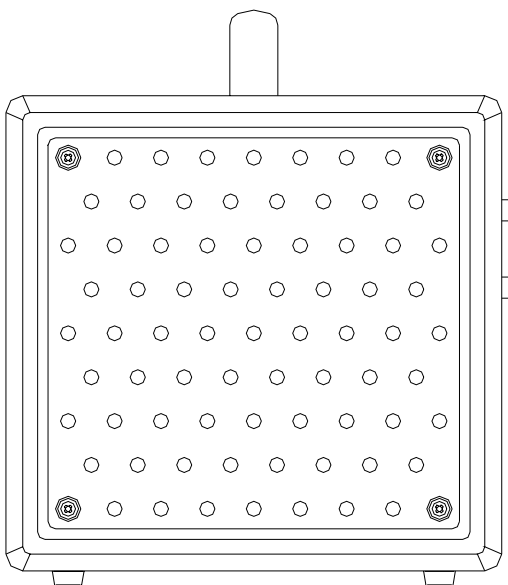
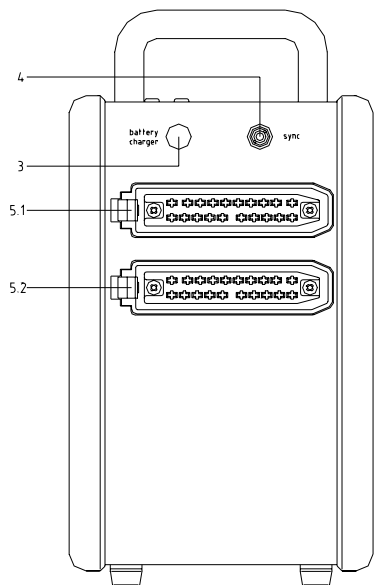

Operation with Studio Booster

- 16. Plug-in Studio Booster
- 16.1 Connection socket
- 16.2 Ready display
- 16.3 Fuse
- 16.4 Mains (AC-line) switch
- 16.5 Warning signal
- 16.6 Contact plug
- 16.7 Connecting screw

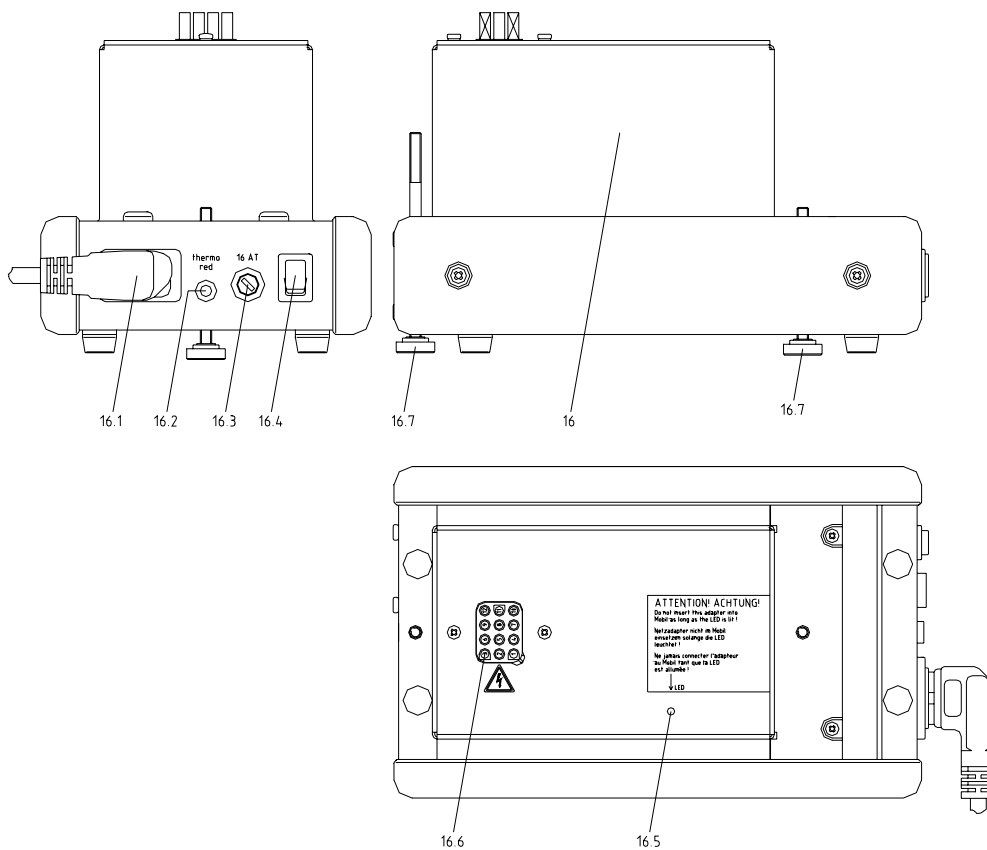

1. Startup

1.1 Battery operation

1.1.1 Startup

Remove protective cardboards from battery contacts before use.

Use the switch "on/off" (1) to power up the unit and check the display "charge state" (14). If the stored energy of the battery is less than 10 % it must be charged by means of the charger (charging time approx. 3 hours for approx. 80 % of charge) or change to another battery. Before powering up the unit for the first time, it is recommended to charge the battery.

1.1.2 Changing the battery

Switch-off the unit before changing the battery.

Please check the contact surfaces of the battery for soiling to guarantee a good contact. Prior to inserting the battery ensure that the side with the contacts is directed to the opening of the power pack compartment.

Now slide the battery into the power pack compartment and use a slight pressure to fasten it. Make sure that the contact springs in the battery compartment are not dirty or damaged. When changing the battery press the locking mechanism (at the bottom) together using finger and thumb. The two big contact springs slide the battery out so far that the user may grip it.

1.2 Operation with Studio Booster

When using the plug-in Studio Booster (16) the unit becomes a complete studio power pack. With the Studio Booster the Mobil power pack operates on 120 V and 230 V (resp. 100 V and 230 V for the Japanese version). After disconnecting from the mains (AC-line) supply all the settings are stored for a short time except the modelling light proportionality level. The modelling lamps in use must correspond to the respective mains (AC-line) voltage. The Studio Booster is connected by tightening the two screws on the bottom simultaneously instead of inserting the battery in the power pack.

Attention:

- Before inserting the Studio Booster into the unit or removing it the mains (AC-line) switch (16.4) on the Studio Booster must be turned off.
- The Studio Booster must only be operated when the warning indicator on the upper side is not lit, and the unit must only be powered-up when the adapter (Booster) is correctly screwed in.
- Use only earthed mains (AC-line).

On the front side of the Studio Booster is an operating indicator LED (16.2). This lights green when the mains (AC-line) switch is turned on. When the integrated thermal protection becomes active after longer flash series, this lights red during the cooling time.

1.2.1 Startup

Use the switch "on/off" (1) and the mains (AC-line) switch (16.3) to power-up unit. During the charging process the digital master power (8) flashes, after which it becomes continuous.

2. Energy control

2.1 Mobil

Use the "up/down" keys (6) to control the flash energy within a range of 4 f-stops. A value of 10 in the display indicates maximum energy, 6 minimum. Whole numbers are full f-stop intervals, decimals indicate 1/10 f-stop steps. Brief pressure on the "up/down" keys (6) runs the power up (or down) by a 1/10 f-stop interval, prolonged pressure by a full f-stop. The display (8) then blinks until charging or discharging has stabilized the new level.

3. Modelling light

3.1 Battery operation

The "mod" key (12) switches the modelling lamps on or off for all connected lamp bases. When switched on, the green LED lights up. With regard to the control of the modelling light this power pack has an automatic switch-off during battery-powered operation. If the "mod" key is pressed again within 1,5s after activating the modelling light, the switch-on time will be extended, with each pressure of the key, by a further 20s. By pressing the "mod" key, once only, to activate the modelling light, the switch-on time is 20s. If the key is pressed 4 times consecutively the maximum switch-on time of 80s is attained. An audible signal sounds with each pressure of the key. This function ensures a prolonged battery service life.

Specially for mobile work with this battery-operated power pack broncolor offers the small lamp Mobilite, with built-in reflector and modelling light 12 V / 50 W and own accessories with small dimensions. The lamp has an automatic thermal protection to prevent overheating and an additional switch for the modelling light. The switch on the lamp base permits selective lighting control with the modelling light. If only one lamp is connected, it can be equipped with a modelling lamp 12 V / 100 W.

The Mobil power pack can also be used with conventional broncolor studio lamps (Picolite, Pulso and Unilite lamps). The modelling light cannot be used during battery operation.

The proportional modelling light is not working during battery operation (Mobilite).

Damage to the modelling lamp or power pack is impossible due to plug coding and electronic protection circuit.

3.2 Operation with Studio Booster

When operating the power pack with Studio Booster the 12 V modelling light as well as the cooling fan of the small lamp Mobilite is not operating. The modelling light of the broncolor studio lamp bases (Picolite, Pulso and Unilite lamp bases) functions normally. When using the mains (AC-line) adapter you may operate the modelling light proportionally (see chap. 3.2.1) and adapt it to various output ratings of broncolor power packs and monoblocs. Furthermore, the automatic switch-off after 20 – 80 s ceases. Damage to the modelling lamp or power pack is impossible due to plug coding and electronic protection circuit.

3.2.1 Proportionality

The brightness of the modelling light can be set proportionally to the flash intensity. To assure proportionality when operating units with different power output ratings, the units have various proportionality levels. These are guaranteed if the identical prop level has been set for all power packs. The higher the digit, the brighter the modelling light. When using the Mobil with two lamps it must be turned down one level lower than the other power packs.

The proportionality level of the modelling light can be selected by a long pressure on the "mod" key when the modelling light is off (12). Repeated actuation of the "up/down" key (6) toggles through the following operating modes:

- P This level can be selected if only D160s are being used (highest proportionality level). Proportional modelling light rated 1200 J.
- P1 Proportional modelling light with broncolor power packs rated 6400 J.
- P2 Proportional modelling light with broncolor power packs rated 3200 J.
- P3 Proportional modelling light with broncolor power packs rated 1600 J.
- P4/5 If a Mobil power pack is operated at a relatively low output level, the halogen modelling light will be relatively weak and yellowish. To counteract this problem, the Mobil is equipped with two additional modelling light proportionality levels: P4 for 800 J and less, P5 for 400 J and less.
- HI The unit operates with full modelling light power independent of the selected flash output.
When the "mod" LED is blinking, the HI level can also be selected by pressing the "up" or "down" key (6) for a longer period of time.

After the setting has been performed, the standard display can be activated by briefly pressing the "mod" key.

Pressing the "mod" key for 1 second when the modelling lamp is on will give direct access to the HI mode. To return press "mod" again.

Please note: When the master switch of the Studio Booster is turned off, the setting will revert to P3 when re-starting.

4. Release and remote control

4.1 Photo cell (cell) and Infrared receiver (ir)

The photo cell can be switched on or off by using the "cell" key (9), the infrared receiver by using the "ir" key (11). If they are activated the green LED light(s) up.

4.2 Infrared flash release channel

Mobil power packs can be triggered with broncolor infrared transmitters. If the power pack is triggered via infrared, the flash release follows with a time delay of 1/1000 s. The power pack can be triggered as soon as 100 % of the charge are reached.

4.3 Sync socket (4)

Synchronous cables art. no. 34.111.00 or 34.112.00 may be plugged into the socket to release flashes via cable.

4.4 "test" key (13)

Key (13) allows the Mobil to be manually released.

5. Flash ready signals visual / audible

5.1 The **visual** ready signal is the green LED at the "test" key (13). It lights up only when the unit is fully charged. After a flash this LED goes out and lights up again when the unit is fully charged once more.

5.2 The **audible** signal (buzzer) sounds when the power capacitors are at 100 % charge. It may be switched on or off. This is explained in chapter 6.3.

- 5.3 Audible alarm signal
When the flash discharge fails, an audible warning signal of approx. 3 s duration will sound.

6. Selecting additional functions

6.1 Switch "eco" (2)

By using the key "eco" (2) the power pack switches to slow charge. This results in an increased number of flashes per charge and a longer battery service life (see chap. 9). This key only functions when in battery operation.

6.2 Automatic switch-off

The power pack switches-off automatically after a selectable delay time. A delay time of 15 min. is factory-set.

Setting of the delay time (in min.):
- **Press the "up/down" keys (6) simultaneously once.**
Afterwards, the minute values are set with the same keys. 3 s after setting the display returns to the energy display.

6.3 Buzzer

The audible signal sounds when the power capacitors are at 100 % charge. The signal may be switched on or off.

- **Press the key "eco" (2) for 3 s.**

7. Protective facilities / Fault indication

7.1. Monitoring in the power pack

To protect against overheating after long series of flashes with battery operation, the unit will switch automatically to slow charge. The green "eco" LED lights up. If nevertheless, the temperature continues to rise (e. g. due to external influence), the unit will block. The message "th" will appear on the LCD display (8) until the unit has cooled down sufficiently and is again ready for operation. If overheating occurs during operation with the Studio Booster the operating indicator LED (16.2) will change from green to red until the unit has cooled down.

If the power pack is unable to charge properly the LCD display (8) will show the message „A1“. This can happen when there is afterglow of a flash tube or when the battery is defective. The alarm will disappear after the fault has been corrected, and subsequently switching the unit off and on again.

In case the voltage of the battery should sink extensively, the message "A2" will appear on the LCD display (8). The unit is blocked for further triggering until the battery is charged.

Units delivered from December 99 have an emergency stop switch. This completely separates the battery from the unit when the battery is in danger of becoming flat. In this situation the unit does not react to key operation. The battery must then be charged and re-inserted in the unit.

If the alarms “A1” or “A2” continue to appear on the LCD display (8) after changing the flash tube or the battery respectively, it is a must to contact the service station.

The message “A3” on the LCD display (8) indicates a technical defect. The unit must be brought to the service station for a check.

If there is no flash discharge after a flash release (e. g. if a flash tube is not connected in the lamp), an audible alarm signal will sound.

7.2 Thermal protection Mobilite

When the lamp base temperature rises during operation, the cooling fan will switch on when necessary. If high temperatures build up due to longer, faster flash series (e. g. operation with power pack Grafit) the flash triggering will be blocked.

8. Maintenance of rechargeable batteries

8.1 Battery care

The battery used is sealed and does not require any special care. It does not show any particular "memory effect" and does not need to be discharged regularly. Therefore it is recommendable to leave the battery connected to the charger when not in use. Ensure, however, that the battery does not discharge too far down as the unit will switch off automatically when the battery voltage sinks too low. As a leakage current flows even when the unit is switched off, **it is highly recommendable** to charge the battery after use, and to leave it connected to the charger when not in use. If this is not possible, you need to charge the battery all three months completely.

8.2 Battery charger

The battery can be charged in or out of the unit as the power pack as well as the battery compartment are fitted with the necessary round plug. The charger no. 36.121.00 charges the battery in two levels, which are displayed by the integrated LED:

LED is lit continuously: The battery is charged in quick charge mode up to approx. 80 % of full charge. Duration depending on state of charge up to 3 hours.

LED is flashing: The battery is being recharged slowly to 100% (duration up to approx. 5 hours) and then kept on charge.

LED is flashing green: The battery is kept on charge

If a defective battery is connected or one with very low voltage then the LED does not blink anymore. In this case the battery must be replaced.

8.3 Charging battery on cigarette lighter

The connecting cable no. 34.113.00 is designed to charge the battery by means of a cigarette lighter of a car or goods vehicle with 12V battery. The charging time remains about the same as mentioned above.

9. Lamp bases

9.1 General

The flash energy is distributed symmetrically to the lamps connected.

The Mobil power pack can basically be operated with all lamps of the broncolor range upto 3200 J. Specially for mobile work with this battery-operated power pack broncolor offers the small lamp Mobilite art. no. 32.010.00 with built-in reflector and halogen light 12 V / 50 W, and own accessories with small dimensions identical to the Picolite accessories. The Pulso adapter art. no. 33.501.00 allows the use of light reflectors and accessories from the Pulso range. If the Mobil power pack is being operated with battery, the modelling light of the traditional broncolor studio lamp bases cannot be used.

More details about the small lamps Mobilite and Picolite may be found in the corresponding product information.

9.2 Replacing flash tubes and halogen lamps

Prior to any change of the flash tube, the lamp base must be disconnected from the power pack! Halogen lamps and flash tubes can be plugged in.

To change the flash tube and halogen lamp release the spring ring and remove the protecting glass. The flash tube must be pulled out straight along the lamp base axis. When inserting the tube be sure that it is fully pushed in.

Taking the lifespan into consideration, the halogen lamp should not be handled with bare hands. Finally, replace the protecting glass and fasten with the spring-ring. The protecting glass is available in the versions "UVE" art. no. 34.332.55 (5500 K) and "UVE matt" art. no. 34.335.55 (5500 K).

9.3 Lamp base plugs

The lamp base plugs and sockets carry mechanical interlocks to prevent inadvertent disconnection. To unplug, push down the locking spring below the cable guide and lift out the plug.

9.4 Extension cable to Mobilite

The extension cable (3,5m), available as accessory with the article no. 34.150.00, is especially thin and flexible. It can only be used with the Mobilite. Should this cable be used with other lamps the modelling light and fan will not function.

9.5 Fuses

Only sand-filled fuses of the type indicated on the type plate may be used; otherwise the halogen lamp may explode.

10. Technical data

	Battery operation	Operation with Studio Booster
Flash energy	1200 J	1500 J (Japan: 1200 J)
F-stop at distance of 2 m (6 1/2 ft), 100 ISO, reflector P70	45 6/10	45 9/10 (Japan: 45 6/10)
Flash duration t 0.1 (t 0.5)	for 1 lamp: 1/230 (1/680) s for 2 lamps: 1/360 (1/1100) s	for 1 lamp: 1/220 (1/650) s for 2 lamps: 1/330 (1/1000) s
Charging time (for 100 % of selected energy)	quick charge: 1.5 - 6 s	230 V / 50 Hz: 0.6 - 2.4 s 120 V / 60 Hz: 0.6 - 2.4 s 100 V / 50 Hz: 0.7 - 2.9 s
Can be switched to slow charge mode	slow charge to prolong battery life: 2 - 13 s	no slow charge
Ready display	visual and audible (can be switched off); signals when 100 % of selected energy is reached	
Lamp base outlets	2	2
Power output distribution	symmetrical	symmetrical
Controls	fully illuminated silicone keyboard as well as LED and LCD display, resistant to dust and scratches.	
Control range	over 4 f-stops in 1/10 f-stop intervals (1:16)	
Modelling light (Halogen)	2 x 50 W or 1 x 100 W	200-240 V: 2 x 650 W 100-120 V: 2 x 300 W
Modelling light control	automatic switch-off after 20 - 80 s to prolong battery life	full, proportional to flash energy, 5 prop levels, adjustable to other broncolor power packs and monoblocs and their various output ranges
Flash release	manual release button, photocell (can be switched off), infrared receiver (can be switched off), sync cable, FCM 2, FCC, IRX 2	
No. of flashes per fully charged battery	quick charge: approx. 100 at full output slow charge: approx. 140 at full output	
No. of sync sockets	1	1
Stabilized flash voltage	± 1 %	± 1 %
Standards	EC standard 73/23, UL 122	
Power requirements		220-240 V / 50 Hz: 10 A 110-120 V / 60 Hz: 16 A 100 V / 50 Hz: 16 A
Dimensions	235 x 144 x 275 mm	235 x 144 x 332 mm
Weight kg	7 kg	

Subject to change in the interest of product enhancement.