

Operating Instructions



broncolor 1600 B

Before use

Please read all the information contained in these operating instructions carefully. They contain important details on the use, safety and maintenance of the appliance. Keep these operating instructions in a safe place and pass them on to further users if necessary.

Observe the safety instructions.

Contents	page
Safety information	4
Controls and displays	5
1. brnccolcc 1600 B	6
2. Application	6
3. Commissioning	6
4. Flash tube / Protecting glass	7
5. Modelling lamp	7
6. Fuse	7
7. Heating / Temperature monitor	8
8. Afterglow blackout	8
9. Mounting	8
10. Changing of reflectors	8
11. Mounting of barn doors	9
12. Umbrella bracket	9
13. Flash release	9
14. Service and repair	9
15. Technical data	10
16. Order numbers for diverse spare parts / Accessories	10

Safety information

Attention: Read before startup

- Prior to replacing the fuse, halogen lamp or flash tube, discharge the unit and disconnect from power. Allow the unit to cool off for 10 minutes before replacing the lamp or flash tube.
- Only those types of fuses indicated on the fuse label may be used. This is particularly important for fusing the halogen lamp which may burst if the wrong fuse is used.
- Only sand-filled fuses may be used. Sand-filled fuses can be identified by the opaque body of the fuse.
- The devices are designed for use in dry rooms. Protect them against splash water and against excessive exposure to dust.
- The devices are not suitable for use in an environment with risks of explosion.
- The accessories mounted to the unit may heat up to high temperatures under specific conditions. Handle with care !
- To protect against the effects of radiated heat, the unit must not be pointed at flammable surfaces from less than 1 meter away.
- Do not block the cooling louvers on the unit.
- Flash light contains, similar to sunlight, a specific portion of UV light. The undesirable side effects on skin and eyes are considerably reduced by using flash tubes with UV coating. Without these or other protective filters, use extreme care when shooting.
- Even when disconnected from power, dangerous voltages may remain within the interior of the device. For this reason, devices should be opened by our broncolor repair service.
- For safety reasons, never operate a unit without the protecting glass in place.

Controls and displays

1. Flash release key
2. Jack for synchronous cable
3. Flash ready control lamp
4. Connection socket for mains cable
5. Fuse
6. Switch for modelling light (proportional/full)
7. Switch for modelling light (on/off)
8. Main switch (on/off)
9. Slave cell (on/off)
10. Rotary switch for power control
11. Switch for dim function (flash release control)

Front panel of broncolor 1600 B

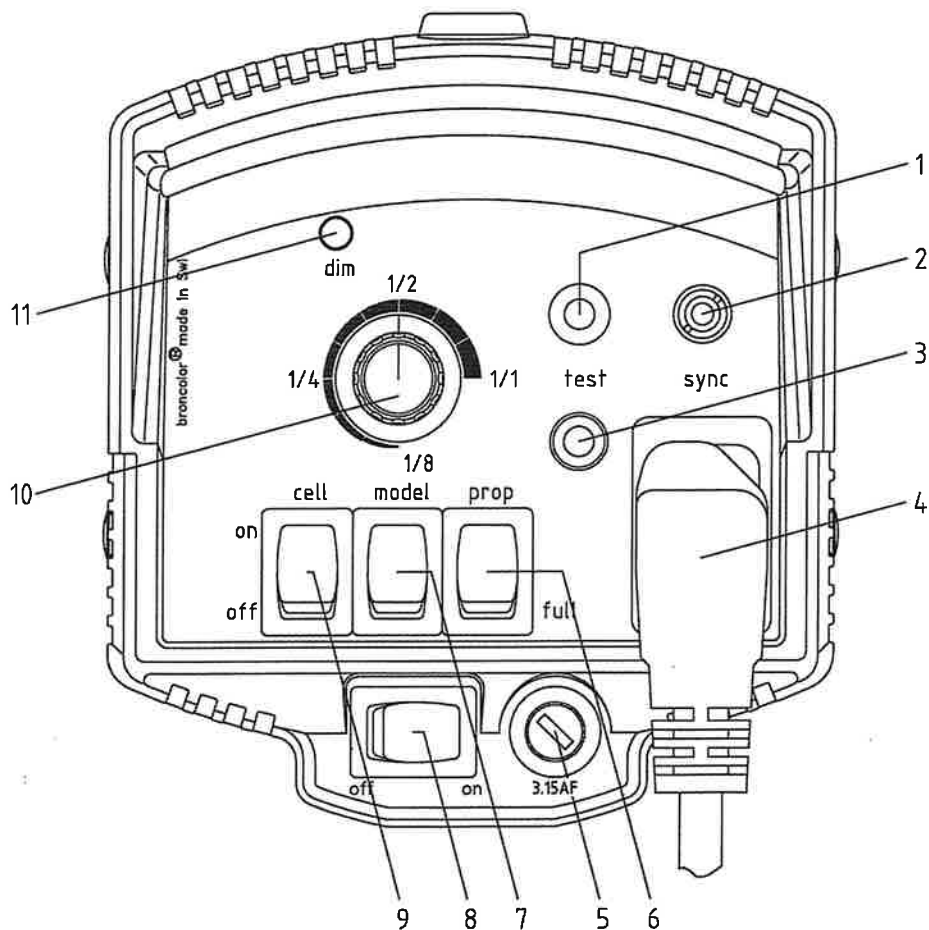

1. broncolor 1600 B

We are delighted that you have chosen the high quality product broncolor 1600 B. With proper care it will render you many years of good service.

2. Application

This mains supplied studio flash unit is designed for professional photography only. In countries with earthed mains systems, use a three-wire extension cable whenever needed.

3. Commissioning

- 3.1 Remove grey plastic hood by rotating. Insert desired reflector and protecting glass and rotate in any direction.
- 3.2 Please check that the mains supply corresponds to the information on the label of the unit. Connect unit to earthed power.
- 3.3 Switch on main switch (8) and modelling light (7).
- 3.4 The modelling light can be switched off or on during charging (dim function) by pushing in switch (11) with a small screwdriver. This option allows the photographer to confirm visually that all the broncolor 1600 B units have fired.
- 3.5 Set intended flash output via control knob (10).
- 3.6 Green control lamp (3) will illuminate: this is how the unit shows that it is ready.
- 3.7 Release test flash by pressing key (1).
- 3.8 Switch photocell (9) on or off, depending on the shot-situation.
- 3.9 If needed, plug in synchronous cable (2).

4. Flash tube / Protecting glass

The flash tube is coated to achieve an optimal colour temperature. For your security, only original flash tubes should be used. For safety reasons, never operate a unit without the protecting glass in place.

4.1 Changing of the flash tube:

1. To replace it, fire a flash, disconnect unit from power, and allow to discharge and cool off for ten minutes (to ensure that the flash capacitor has discharged).
2. Remove the protecting glass.
3. First pull out the triggering cable and then the flash tube (do not touch with bare hands).
4. Insert the new flash tube.
5. Insert the triggering cable.
6. Replace the protecting glass.
7. Plug in the unit, now it is ready for use.

5. Modelling lamp

The units are equipped with a very bright 150 W halogen modelling light. The halogen lamp can be plugged in, when exchanging, beware of touching the lamp with bare hands.

Please note, that you must pull out the flash tube before exchanging the modelling lamp.

6. Fuse

The fuse (5) is located on the rear of the unit. Sand-filled fuses with a value 3.15 AF may only be used (sand-filled fuses can be identified by their opaque fuse container). Using an incorrect fuse is dangerous: it may cause the halogen lamp to burst. The correct fuse is therefore included with each original broncolor replacement lamp.

7. Heating / Temperature monitor

In the proximity of the halogen lamp, the unit, depending on adapters used, can acquire high temperatures. For this reason, we recommend touching the unit on the handle behind or on the stand adapter only. Due to the intense heat radiation when a modelling light is in operation, keep the unit at a minimum distance of 1 m from flammable surfaces.

The unit contains a temperature sensor which protects the electronic circuitry from overload during long flash sequences. If the safety system is activated, the modelling light goes out and charging is blocked. The ready indicator light changes to red until the unit has cooled off. The fan will continue to operate to promote faster cooling.

8. Afterglow blackout

The unit is equipped with an automatic afterglow blackout. If the flash tube begins to exhibit afterglow (at the end of its service life, for example), this blackout blocks further charging to prevent any additional damage. The ready indicator light also glows continuously red to indicate this condition. To cancel the blackout, switch the unit off and then on again.

9. Mounting

The stand adapter is located below the housing. The adapter will accept standard broncolor[®] bolts and Manfrotto[®] pins.

Make sure the lamp is firmly attached to the stand before operating. The click-stops of the locking handle can be adjusted by pulling it out.

A locking pin is screwed into the lower part of the stand adapter so it can be hung from a broncolor[®] bolt; this is not required for stand mounting, and must be removed. A safety cable must be installed whenever the lamphead is suspended.

10. Changing of reflectors

Reflectors and accessories are provided with an adapter which is to be fixed to the bayonet mounting with a slight turn.

11. Mounting of barn doors

The barn doors are inserted on the mounting supports of the reflector.

12. Umbrella bracket

The umbrella reflector (art. no. 53.457.00) is used in conjunction with umbrella diffusers and reflectors. The umbrella handle is inserted into the special holder in the stand adapter.

13. Flash release

The release is possible via sync cable, photocell or with trigger button.

The units are fitted with a synchronous circuit with low working voltage to protect the camera contact. This synchronous contact may not be switched parallel with outside brands since the latter work with high synchronous voltage.

When releasing by the slave cell make sure that the receiver cell of the unit is not blocked by obstacles.

As the photocell is also sensitive in the infrared range, the unit can be triggered, wirelessly, via a small flash unit on the camera fitted with an IR-permeable filter.

14. Service and repair

Your broncolor monobloc is a precision device which will work for many years without malfunctions if you take proper care of it. If malfunctions do arise, please do not attempt to open the unit so as to repair it yourself. Even when the unit is shut off, dangerous voltages may remain within the interior of the device. Leave service and repairs to our broncolor repair service.

15. Technical data

F-stop at 1 m (ISO 100, standard reflector)	64
Flash duration (t 0.5)	1/600 s
Charging time (for 100 % of selected energy)	0.7 - 1.9 s
Ready indicator	visual at 100 % of selected energy
Adjustment range	stepless over 3 stops
Modelling light	halogen 150 W
Flash triggering	sync cable, IR-sensitive photocell (can be switched off), manual release button
Reflector mount	patented twist-on bayonet
Stabilized flash voltage	± 1 %
Power requirements	200 - 240 V, 50 Hz: 10 A
Interference suppression	SEV, VDE
Dimensions (not including handle)	120 x 195 x 410 (mm)
Weight	2.9 kg

Subject to change in the interest of technical development.

16. Order numbers for diverse spare parts / Accessories

Flash tube coated for broncolor 1600 B	art. no. 54.301.00
Halogen modelling lamp (150 W / 230 V)	art. no. 54.252.XX
Protecting glass, clear for broncolor 1600 B	art. no. 54.400.59
Fuse 3.15 AF	art. no. 37137.00
Transport protection cap, grey	art. no. Z6098.00
Mains cable Europe 200 - 240 V	art. no. 39086.00
Mains cable USA 100 - 120 V	art. no. 39085.00
Sync cable	art. no. 54.104.00

CE

Printed in Switzerland 07.06

Bron Elektronik AG
CH - 4123 Allschwil
Schweiz (Switzerland)

THE LIGHT